

Problems for Physics 111: *Electricity, Magnetism, and Thermodynamics*

Dan Styer; April 2023

1. *Using Coulomb's law*

Two point charges $+q$ and $+4q$ are a distance L apart. A third charge is placed so that the entire system is in equilibrium. (a.) Find the location, magnitude, and sign of the third charge. (b.) Show that the equilibrium of the system is unstable.

2. *Hanging charges*

Two tiny balls of identical mass m and identical charge q hang on two threads of length L attached to one point on the ceiling. The distance x between the two balls is much less than the string length L .

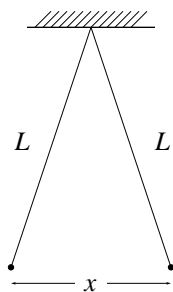

- a. Show that the distance between the two balls is approximately

$$x \approx \left(\frac{1}{4\pi\epsilon_0} \frac{2q^2 L}{mg} \right)^{1/3}.$$

- b. Suppose the mass m were increased. According to the formula, would the separation x increase or decrease? Does this make sense to you? Repeat for increases of g , q , and L .
- c. Does it make any difference whether the charge q on each ball is positive or negative? This is called “symmetry under interchange of the sign of q .” Does this symmetry hold only in the approximation $x \ll L$?
- d. What would happen if the two charges were not equal but instead there was charge q_L on the left ball and q_R on the right ball? (Both charges being of the same sign.)

3. *Estimating charges and forces*

Two students, Ivan and Veronica, stand about 100 feet apart. Ivan weighs about 200 pounds and Veronica weighs about 100 pounds. Suppose each student has a 0.01% excess in his or her amount of positive and negative charge, one student being positive and the other negative. Estimate the force of attraction between the two. (*Clues:* Students consist mostly of water, and for this purpose they may be considered to be points.)

4. *Electric field due to two charges*

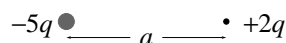

(a.) In the situation above locate the point or points at which the electric field due to the two charges is zero. (b.) Sketch the electric field lines qualitatively.

5. *Clock of charge*

A clock face has negative point charges $-q, -2q, -3q, \dots, -12q$ fixed at the positions of the corresponding numerals. The clock hands do not perturb the net field due to these twelve source charges. At what time does the hour hand point in the direction of the electric field vector at the center of the dial? (*Clue:* Use symmetry.)

[I apologize for the rather artificial character of this problem, but I feel that the thrill of finding a clever solution to an apparently monstrous problem is adequate pay back.]

6. *Rod of charge*

A thin non-conducting rod of length L has a charge $+q$ spread uniformly along it. We wish to find the electric field due to the rod at point P a distance y above the rod's midpoint.

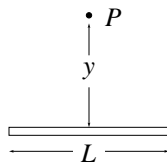

- a. Argue from symmetry that the electric field at point P must point either directly away from or directly toward the rod's midpoint.
- b. Find the magnitude of the electric field at point P . (This involves evaluating a moderately difficult integral. Feel free to use a computer algebra system or a table of integrals.)

—continued on next page—

- c. Four friends work part (b) of this problem independently. When they get together to compare results, they find that each of the four has obtained a different answer! The four candidate answers are

$$E(y) = \frac{1}{4\pi\epsilon_0} \frac{q}{y\sqrt{y^2 - (L/2)^2}}, \quad (1)$$

$$E(y) = \frac{1}{4\pi\epsilon_0} \frac{q}{y\sqrt{y^2 + (L/2)^2}}, \quad (2)$$

$$E(y) = \frac{1}{4\pi\epsilon_0} \frac{q}{y\sqrt{y^2 + (L/2)^2}}, \quad (3)$$

$$E(y) = \frac{1}{4\pi\epsilon_0} \frac{q}{y\sqrt{2y^2 + (L/2)^2}}. \quad (4)$$

Show that one candidate answer is dimensionally incorrect, one gives nonsense for perfectly legitimate values of y , and one gives an incorrect result for the special case $L = 0$. The remaining candidate is correct. (These sorts of plausibility tests are discussed in the “Answer Checking” section of the document “Solving Problems in Physics” at <http://www.oberlin.edu/physics/dstyer/SolvingProblems.html>.)

- d. Does the correct expression for $E(y)$ have the expected functional dependence on y , q , and L ?

- e. Show that this electric field approximates that of a point charge when $y \gg L$.

7. Card of charge

A thin non-conducting card of length $2a$ and width $2b$ is painted uniformly with charge $+q$. We ask about the electric field due to the card at the point a distance z above the center of the card. The electric field there of course points straight away from the card, but what is its magnitude? Four candidate answers are

$$E(z) = \frac{1}{4\pi\epsilon_0} \frac{q}{z\sqrt{4z^2 + a^2 + b^2}}, \quad (1)$$

$$E(z) = \frac{1}{4\pi\epsilon_0} \frac{q}{z\sqrt{z^2 - a^2 - b^2}}, \quad (2)$$

$$E(z) = \frac{1}{4\pi\epsilon_0} \frac{q}{z\sqrt{z^2 + 2a^2 + b^2}}, \quad (3)$$

$$E(z) = \frac{1}{4\pi\epsilon_0} \frac{q}{z\sqrt{z^2 + a + b}}. \quad (4)$$

Show that *all four* of these candidates are incorrect because they are impossible, algebraically improper, give an incorrect special case, or lack a required symmetry. (In fact, the correct expression turns out to be

$$E(z) = \frac{1}{4\pi\epsilon_0} \frac{q}{ab} \arctan \left[\frac{ab}{z\sqrt{z^2 + a^2 + b^2}} \right],$$

although this is a rather difficult result to uncover.)

8. *Antisymmetric charge distributions*

A thin glass rod is bent into a semicircle. The charge $+q$ is painted uniformly on the upper half, and the charge $-q$ is painted uniformly on the lower half.

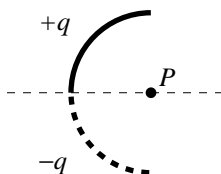

- Show that the electric field at point P points straight downward.
- Show that the electric field at any point on the horizontal line passing through P points straight downward.
- If a two-dimensional charge distribution has a line such that any charge below the line has a corresponding charge of the same magnitude but opposite sign at the same position above the line, and vice versa, then that line is called an axis of antisymmetry. Show that the electric field at any point on the axis of antisymmetry must lie within the plane of the charge distribution and point perpendicular to the axis.

9. *Flux in the Earth's atmosphere*

The Earth's atmosphere typically has an electric field (the "fair weather field") related to thunderstorms elsewhere on the planet. It is found by experiment that the electric field in a certain region of the Earth's atmosphere is directed vertically down. At an altitude of 300 m the field has magnitude 60.0 N/C; at an altitude of 200 m, 100 N/C. Find the net charge contained within a cube 100 m on edge, with horizontal faces at altitudes of 200 m and 300 m. (All data have three significant figures. It's clear from the statement of this problem that the curvature of the Earth is negligible in this context.)

10. *Field due to a pipe of charge*

A long, thin-walled metal tube of radius R carries a charge per unit length of λ on its surface. Derive an expression for the magnitude of \vec{E} in terms of distance r from the tube axis, considering both $r < R$ and $r > R$. Sketch this function.

11. *Hanging from a charged wall*

A tiny ball of mass $m = 1.0$ mg and charge $q = 2.0 \times 10^{-8}$ C hangs from an insulating thread that makes an angle $\theta = 30^\circ$ with a vertical, insulating, uniformly charged wall (shown in cross section). The wall extends a long distance vertically and into and out of the page. Considering the gravitational force on the ball, find the surface charge density σ on the wall.

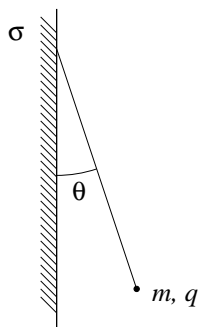

12. *The thick shell of charge*

A thick spherical shell of charge has inner radius a , outer radius b , and uniform charge density ρ . Find expressions for the electric field at any point. Sketch the magnitude of the field as a function of radius r , paying special attention to any discontinuities, kinks, or other unusual features.

13. *Sphere of charge with a spherical cavity*

A non-conducting sphere has a uniform volume charge density ρ . Let \vec{r} represent the vector from the center of the sphere to an arbitrary point P within the sphere.

- a. Show that the electric field at point P is given by $\vec{E} = \rho\vec{r}/3\epsilon_0$. Note that this result is independent of the radius of the sphere.

Now a spherical cavity is hollowed out of the sphere of charge, as shown in cross section below. (This hollowing-out process decreases the total volume of occupied by the charge and thus the total charge, while keeping constant the charge density ρ of the remaining, un-hollowed-out, portions of the sphere.) The vector from the center of the sphere to the center of the cavity is called \vec{a} .

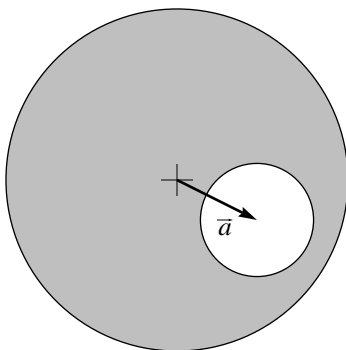

- b. Show that the electric field at the center of the cavity is not affected by the hollowing-out process: it is $\rho\vec{a}/3\epsilon_0$ both before and after the hollowing occurs. (*Clue:* Think of the hollowing-out as proceeding through the removal of one shell at a time.)
- c. By contrast, show that at a point P within the cavity but not at its very center, the electric field *does* change as the hollowing-out proceeds: it starts out as $\rho\vec{r}/3\epsilon_0$ and ends up as $\rho\vec{a}/3\epsilon_0$.

In short, the electric field within the cavity is uniform and equal to $\rho\vec{a}/3\epsilon_0$ at all points. This is a remarkable result: First, the electric field within the cavity is independent of the size of the sphere *and* the size of the cavity. Second, the field due to all these charges bounded by curves sums up, not to a “curvy” field, but to a uniform field.

Note: This is my favorite electrostatics problem. Part (a) is easy. Parts (b) and (c) are algebraically easy, but they rely on thinking about the problem from a particular subtle perspective. (*Clue:* Superposition.) I admit without shame that when I took introductory E&M I never found the proper perspective. . . my teacher had to show me how to do it. If you can’t obtain this perspective then you should (for partial credit) do part (c) for the special case $\vec{a} = 0$.

14. *Charge collected by a satellite*

A spherical satellite of radius 10 m moves through the dilute ionized gas of the Earth's ionosphere. The satellite's potential typically changes by -1.0 V with each orbit. How much charge does it collect with each orbit?

15. *Electric potential due to a washer*

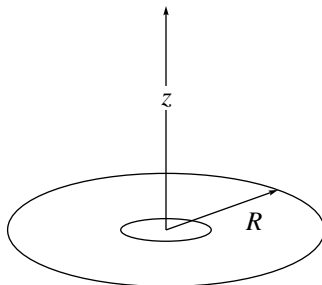

A washer (or annulus) with uniform surface charge density σ has outer radius R and inner radius $R/5$. What is the electric potential due to this charge at distance z above the center of the washer?

16. *Electric potential due to a quarter disk*

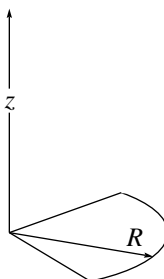

A plastic disk of radius $R = 64.0$ cm is charged on one side with a uniform surface charge density $\sigma = 7.73$ fC/m², and then three quadrants of the disk are removed. The remaining disk resembles a (thick) slice of pie. What is the electric potential a distance $z = 25.9$ cm above the sharp point of the pie slice? Use the standard convention that $V = 0$ far away from the disk.

Clue: Use symmetry together with a result derived in the text. If you try brute force you'll be flattened!

17. *Electric potential energy*

Find the electric potential energy of the square, four-charge configuration shown below.

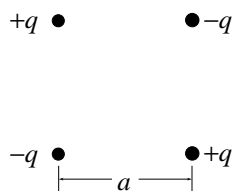

18. *Electric field near two conductors*

In the “Mapping Electric Fields” lab, two conductors used in the pattern shown below. Presented here are five diagrams that purport to show the field lines associated with these two conductors. Using only a sentence or two for each diagram, explain why four of them cannot be correct.

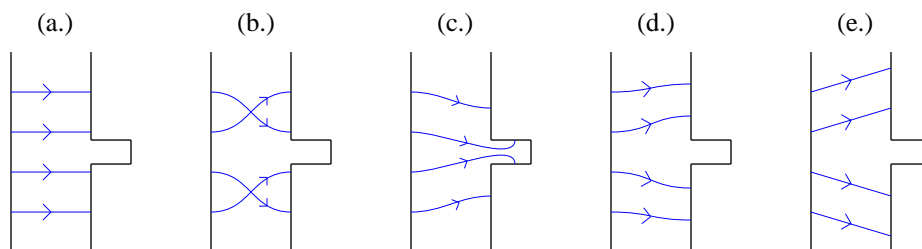

19. *A conductor with a cavity enclosing a charge*

A point charge $+q$ is placed at the exact center of an electrically neutral, spherical, conducting shell with inner radius a and outer radius b .

- a. What charges appear on the inner and outer surfaces of the shell?
- b. Find expressions for the electric field when $r < a$, when $a < r < b$, and when $b < r$. Sketch field lines.
- c. What is the electric field due to the central and inner surface charges alone? Due to the outer surface charges alone? Conclude that the conductor divorces the problem into two separate problems, one inside the cavity and one outside the conductor: The total charge distribution inside the cavity—including the surface charge on the inside of the conducting shell—has no net effect on any point outside the cavity. The total charge distribution outside the conductor—including the surface charge on the outside of the conducting shell—has no net effect on any point within the conductor or the cavity. (This divorce is called “shielding”.)
- d. Why do the field lines from the central point charge stop at the inner surface, whereas the field lines from a single point charge go out to infinity? Does the conducting shell somehow “erase” the field due to the central charge? (*Clue:* What is the electric field at a point \vec{r} inside the shell due to the central charge alone?)
- e. If a second point charge of charge $-q$ is placed outside of the shell, is there any change in the distribution of surface charge on the inside of the conductor? On the outside? Sketch qualitatively the new charge distribution and field lines.
- f. Does the outside charge experience a force?
- g. Does the inside charge experience a force?
- h. Is Newton’s third law violated in this situation?

20. *A conductor with two cavities*

A neutral spherical conductor contains two irregular cavities. A fixed charge of -3 nC is placed within the first cavity and a fixed charge of $+2$ nC is placed within the second. Then a charge of $+5$ nC is placed on the conductor itself

- a. What is the total charge on the outer surface of the conductor?
- b. Is this charge distributed uniformly or non-uniformly? How do you know? (Answers without explanations get zero credit.) (*Clue:* Shielding.)

21. A force field for which no potential exists

Consider a force field $\vec{F}(x, y, z) = (4y + 3)\hat{i}$, where \hat{i} is a unit vector in the x direction. Show that the integral

$$\int \vec{F}(x, y, z) \cdot d\vec{\ell}$$

from $(0, 0, 0)$ to $(2, 1, 0)$ depends upon the path taken by evaluating that integral for the three paths shown in the figure below. (Path A is “right then up”, path B is “up then right”, and path C is “straight on the diagonal line $y(x) = x/2$ ”.)

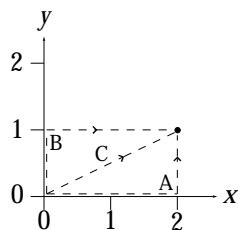

(Answers: A, 6; B, 14; C, 10.)

22. Three charges

Three charged particles are located at three vertices of a square with edge length a as shown. The fourth vertex (point **P**) is empty.

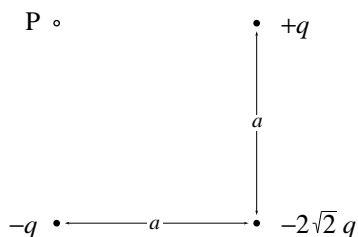

- What is the electric potential at point **P**? Use the convention that the potential vanishes far from the charges.
- What is the magnitude and direction of the electric field at point **P**?

23. *Review of concepts*

The four central quantities of electrostatics are:

name	usage
charge	charge on an object; charge at a point
electric field	field at a point; field due to a particular charge
flux	flux through a surface
potential	potential difference between two points; potential at a point (with reference point zero understood)

- a. Which of these quantities are scalars, and which are vectors?
- b. Which of these quantities are functions of position in space, and which are not?
- c. What are the dimensions of each quantity?
- d. For each phrase below change the underscored words so that the phrase makes sense.
 - i. The flux between two points.
 - ii. The charge through a surface.
 - iii. The potential shooting out through a surface.
 - iv. The charge density through a surface.
 - v. The flux on an object.
 - vi. The electric field between charges B and C.

24. *Capacitance for carpenters*

A metal hand saw carries charge $+70$ pC. A nearby metal wrench carries charge -70 pC. The resulting potential difference between the two objects is 20 V. (a.) What is the capacitance of the system? (b.) If the charges are changed to $+200$ pC and -200 pC, what does the capacitance become? (c.) What does the potential difference become? (All data have two significant digits.)

25. *Force between capacitor plates*

Show that the plates of a parallel plate capacitor attract each other with the force

$$F = \frac{q^2}{2\epsilon_0 A}.$$

One way of doing this is by calculating the work needed to increase the plate separation from x to $x + dx$, with the charge q remaining constant. However, there are other ways as well.

26. *Three-body forces*

The electrostatic force (like the gravitational force) is a *two-body force*, meaning that the force between two point charges is unaltered by the addition of a third point charge. Convince yourself that not all forces are of this type by considering the interaction of an atom and a point charge, and then adding a third point charge. *Clue:* Each point charge will induce a polarization in the atom.

27. *Wire resistance*

A 1.00 meter length of 24 gauge Nichrome wire has a resistance of 4.48Ω . What length of 18 gauge Nichrome wire will give a resistance of 100Ω ? (24 gauge wire has a diameter of 0.0200 inches, while 18 gauge wire has a diameter of 0.0400 inches. . . the lower the gauge number, the thicker the wire. All measurements have three significant figures.)

28. *Electric fields and charges in resistors*

I said in class that positive charge “piles up” where the current enters a resistor and that negative charge accumulates where the current leaves. This problem investigates a simple model of a resistor that illustrates these general facts.

Model a resistor by a cylinder of graphite (C) with resistivity ρ_C ; model the wires leading to the resistor by cylinders of copper (Cu) with resistivity zero. Assume that the wire is straight and that the current density \vec{J} is uniformly distributed throughout the wire.

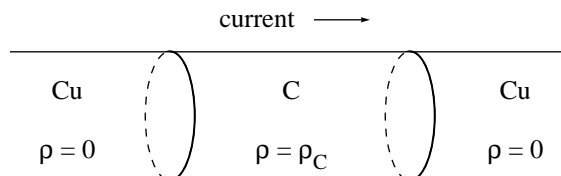

- a. Using the “microscopic form of Ohm’s law”, $\vec{E} = \rho \vec{J}$ (LSM equation 9.6), sketch the field lines that exist inside the wire and the resistor.
- b. Use a Gaussian cylinder straddling the left Cu-C interface to show that a surface charge density $\sigma = \epsilon_0 \rho_C J$ exists on this interface. Similarly show that the right interface carries surface charge density $\sigma = -\epsilon_0 \rho_C J$.
- c. Show that all other points within the wire and resistor carry no net charge.

29. *Automobile gas gauge*

A gasoline gauge for an automobile is shown schematically below.

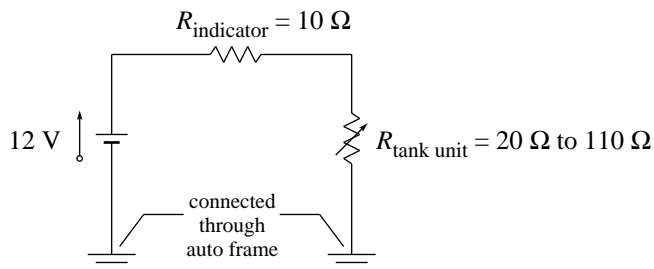

A wire runs from the positive end of the battery (under the hood) to the indicator gauge (on the dashboard, with resistance 10Ω), and another wire runs from the indicator gauge to the tank unit (at the rear of the car). There is no return wire: instead, the negative end of the battery and the bottom end of the tank unit are each connected to the steel automobile frame, and the return current runs through the frame itself. (These two connections are said to be “grounded to the frame”.) The tank unit is a float connected to a variable resistor whose resistance is 20Ω when the tank is full, 110Ω when the tank is empty, and varies linearly with the volume of gasoline. Find the current in the circuit when the tank is (a) full, (b) half-full, and (c) empty.

30. *A circuit with two batteries*

The batteries in this circuit have negligible internal resistance.

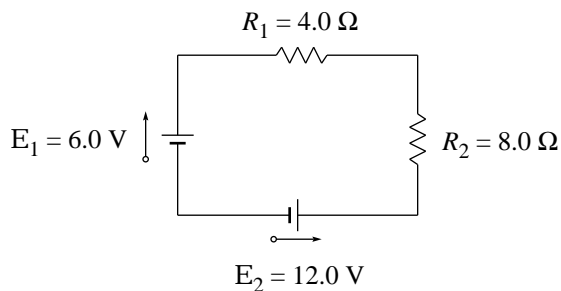

Find (a) the current in the circuit (including direction), (b) the power dissipated in each resistor, and (c) the energy transfer rate (including sign) at each battery.

31. A circuit with four resistors

Find the equivalent resistance of this network and the current through each resistor. (The battery has negligible internal resistance.)

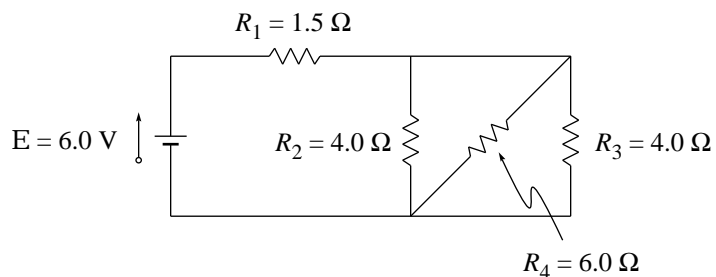

32. A circuit with five resistors

What is the potential difference across the 5.0Ω resistor in the circuit below? *Clue:* Ignore irrelevant data.

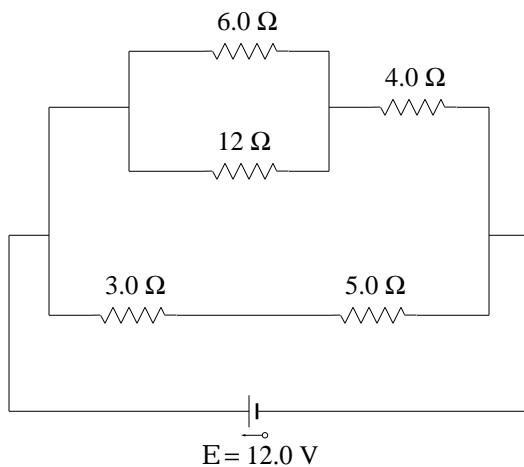

33. *A simple circuit: derivation and exploration*

Three resistors and a battery are connected as sketched below:

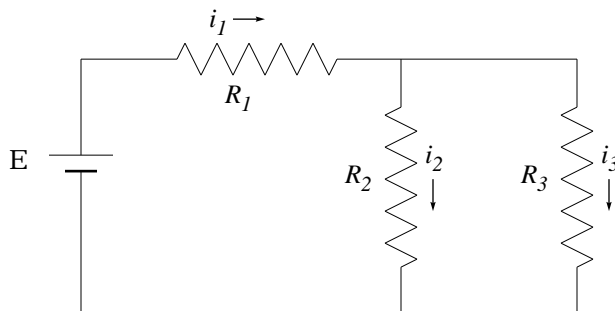

Consider all the circuit elements to be ideal. You know techniques for finding i_1 , i_2 , and i_3 in terms of R_1 , R_2 , R_3 , and \mathcal{E} , but please don't find these expressions yet. Instead, work through the following steps:

- a. Four friends independently find expressions for i_3 . When they get together to compare results, they find that each of the four has obtained a different expression! The four candidate answers are

$$i_3 = \mathcal{E} \frac{R_3}{R_1 R_2 + R_1 R_3 + R_2 R_3}, \quad (1)$$

$$i_3 = \mathcal{E} \frac{R_2}{R_1 R_2 + R_1 R_3 + R_2 R_3}, \quad (2)$$

$$i_3 = \mathcal{E} \frac{1}{R_1 + R_1 R_3 + R_2 R_3}, \quad (3)$$

$$i_3 = \mathcal{E} \frac{R_2}{R_1 R_2 - R_1 R_3}. \quad (4)$$

Show that one candidate answer is dimensionally incorrect, one gives infinite current for perfectly legitimate values of the resistances, two give incorrect results for the special case $R_2 = 0$, and one gives incorrect results for the special case $R_3 = 0$. Verify that the remaining candidate is correct.

- b. In this circuit, if every subscript “2” is changed to a subscript “3” and vice versa, the resulting circuit is exactly the same as the original. Use this symmetry to write down an expression for i_2 directly from the expression for i_3 without any intermediate steps.
- c. Now that you know both i_3 and i_2 , find i_1 through a single addition.
- d. The current leaving the top of the battery and passing through R_1 is i_1 . What is the current entering the bottom of the battery?
- e. If the battery emf \mathcal{E} is tripled, what happens to each of the currents?

—continued on next page—

- f. If every resistance is doubled, what happens to each of the currents?
- g. If R_3 is much greater than R_2 , what is i_3 ? Is this what you expect?
- h. Does current always take “the path of least resistance”?

34. *A circuit with five resistors and two batteries*

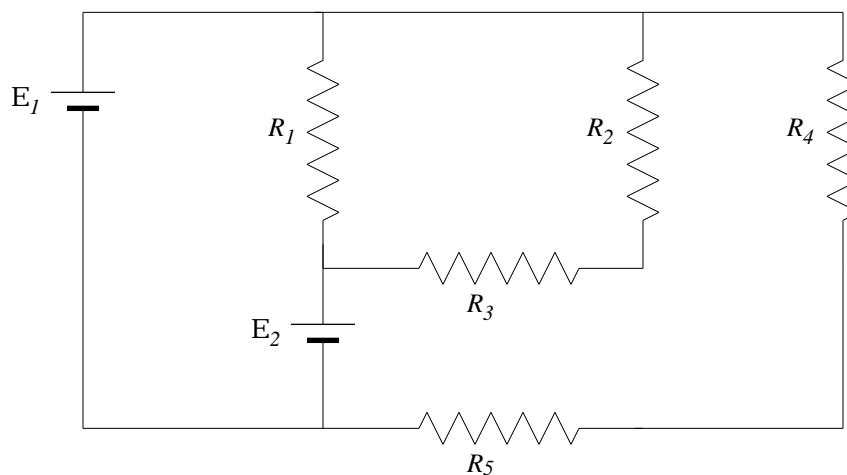

- a. Below are three candidate expressions for the current through R_4 in the circuit sketched above. Without solving the problem, give at least one reason why each candidate *cannot* be correct.

$$\frac{\mathcal{E}_1}{R_4 + R_5 - R_1} \quad (1)$$

$$\frac{\mathcal{E}_2}{(R_2 + R_3)(R_4 + R_5)} \quad (2)$$

$$\frac{\mathcal{E}_1 R_3}{R_2(R_4 + R_5)} \quad (3)$$

- b. Find a correct expression for the current through R_4 .

[*Answers for part (a):* The first candidate gives infinite current when $R_1 = R_4 + R_5$. The second candidate does not have the dimensions of current. The third candidate lacks the required symmetry between R_2 and R_3 . It also shows increased current with increased R_3 —unexpected to say the least—and it predicts infinite current through R_4 if R_3 is infinite (e.g. if the wire between R_2 and R_3 is broken).]

35. *Resistors in parallel*

a. Show that the equivalent resistance of two resistors in parallel is

$$\frac{R_1 R_2}{R_1 + R_2}.$$

b. It is tempting to generalize this result and guess that the equivalent resistance of three resistors in parallel is

$$\frac{R_1 R_2 R_3}{R_1 + R_2 + R_3}.$$

Without doing a derivation, show that this guess is impossible.

c. Find the correct expression for the equivalent resistance of three resistors in parallel.

36. *Resistance measurement*

A voltmeter of resistance R_V and an ammeter of resistance R_A are connected as shown in an attempt to measure the resistance of a resistor.

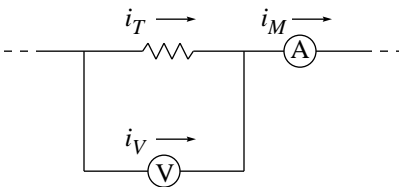

If

$$\begin{aligned} \Delta V &= \text{voltage drop across resistor} \\ &= \text{voltage drop across voltmeter} \\ &= \text{voltmeter reading} \end{aligned}$$

then the true resistance of the resistor is $R_T = \Delta V / i_T$. However the current i_T can't be measured directly — the ammeter measures a slightly different current i_M . Define the “measured resistance” $R_M = \Delta V / i_M$ and show that

$$\frac{1}{R_T} = \frac{1}{R_M} - \frac{1}{R_V}.$$

When R_V is much greater than R_M , how are R_M and R_T related?

37. *Principle of minimum power dissipation*

Part of a circuit consists of two resistors, R_1 and R_2 , in parallel. Current I flows into the top of the pair and out of the bottom. It doesn't matter what is in the rest of the circuit, so I haven't shown it in the figure.

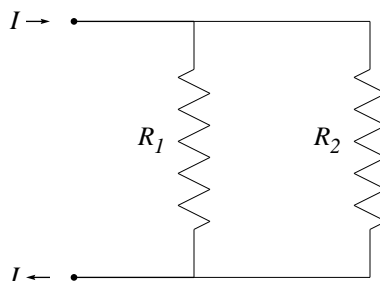

You know that the current I splits up so that i flows through R_1 and $(I - i)$ flows through R_2 (Kirchhoff's junction rule). And you know that you can calculate i by demanding that the voltage drop across R_1 is equal to the voltage drop across R_2 (Kirchhoff's loop rule). This problem demonstrates a different method, the principle of minimum power dissipation, that can also be used to calculate the amount of splitting.

- Find the power dissipated in the two resistors $P(i)$ as a function of i , using only Kirchhoff's junction rule and not Kirchhoff's loop rule.
- Find the value of i that minimizes $P(i)$.
- Show that the value of i obtained in part (b) is the true current through R_1 as obtained through Kirchhoff's loop rule.

Although we have discussed only a single example, it turns out that the principle of minimum power dissipation always gives the correct currents in circuit problems. In most circumstances, it is easier to find currents using Kirchhoff's loop rule rather than the principle of minimum power dissipation, but the principle is nevertheless interesting. For example, it is a special case of the more general principle of minimum entropy production.

38. *Capacitor discharge*

You have two resistors of unknown but identical resistance. A 100 microfarad capacitor is charged by a 1.6 volt battery and then discharged through one of the resistors. The discharge is exponential with a half life (or "halving time") of 26.4 seconds.

Now the experiment is repeated, except that the capacitor is discharged through the two resistors connected in parallel. What will be the half life for this discharge? (As always, explain your reasoning in a sentence or two.)

39. *An application for RC circuits*

The flashing orange lamps attached to barrels at highway construction sites use the circuit below, where L represents an orange fluorescent lamp.

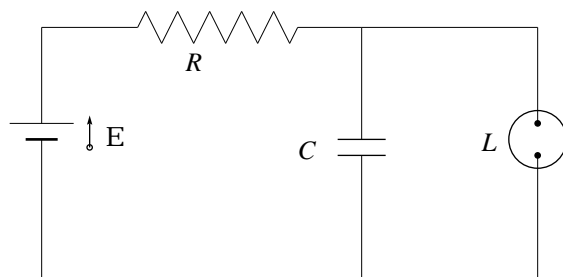

The lamp has these properties: When the voltage across it is less than the “breakdown voltage” V_L , the lamp has nearly infinite resistance. But when the voltage across the lamp reaches V_L , electrons are stripped from the lamp’s gas atoms, creating a plasma with nearly zero resistance, and the lamp flashes.

In this circuit, an initially uncharged capacitor is charged by the battery through the resistor: During this phase, the lamp with nearly infinite resistance might as well be out of the circuit. But once the lamp reaches voltage V_L , the capacitor discharges rapidly and completely through this plasma: During this phase the battery and resistor might as well be out of the circuit.

For a lamp with $V_L = 72.0$ V, wired to an ideal battery with $\mathcal{E} = 95.0$ V and a 0.150 μF capacitor, what resistance R is needed to create two flashes per second?

Answer: 2.35 M Ω .

40. *Television*

Each of the electrons in the beam of a television tube (old style flickering screen, not flat panel) has a kinetic energy of 12.0 keV. The tube is oriented with respect to the Earth’s magnetic field so that electrons move toward magnetic north. The vertical component of Earth’s magnetic field points down and has magnitude 55.0 μT . (a.) In what direction will the beam deflect? (b.) What is the acceleration of a single electron due to the magnetic field? (c.) How far will the beam deflect while moving 20.0 cm through the TV tube?

41. *Protective shield against charged bullets*

A beam of electrons, each with kinetic energy K , emerges from the end of an accelerator tube. A metal plate perpendicular to the tube is situated a distance d from its end. Your job is to make a uniform magnetic field that will cause the electrons to deflect as shown and *not* strike the plate.

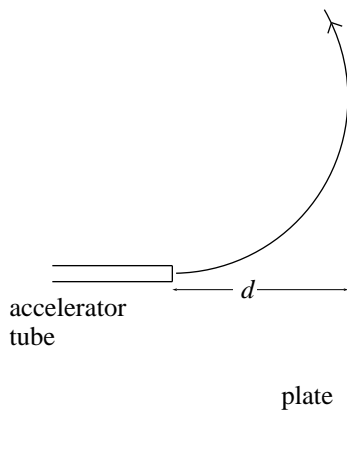

What orientation should the field have? Show that the field magnitude must be

$$B > \frac{\sqrt{2mK}}{ed}$$

where m is the mass and $-e$ is the charge of an electron.

42. *\vec{B} and \vec{E} together*

A region of space is filled with uniform upward-pointing magnetic field \vec{B} and uniform horizontal electric field \vec{E} pointing north. A particle of charge q and mass m is shot into this region horizontally on an east-west axis. The particle is not deflected at all... it travels in a straight line.

- Is the particle traveling to the east or to the west?
- What is the magnitude of the particle's velocity, in terms of the given quantities?
- Your answers should be independent of the sign and magnitude of the charge q , and independent also of the mass m . Can you understand either of these characteristics heuristically?

43. *Primitive motor*

A conducting bar of mass m slides with negligible friction on two long horizontal rails. A uniform vertical magnetic field \vec{B} fills the region in which the rod moves. A constant current generator makes current i run as shown: left on the top rail, down through the bar, and right back to the generator on the bottom rail. This generator produces the same current i under all circumstances, even when the bar moves.

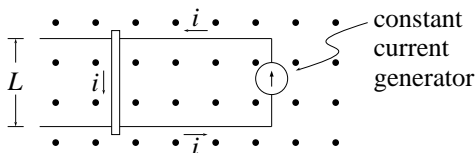

(a.) If the bar is stationary at $t = 0$, what is the speed and direction of the bar's motion as a function of time? (b.) Once the bar starts to move, the total velocity of a charge carrier is the sum of the carrier's velocity relative to the slide wire plus the slide wire's velocity relative to the rails. Why is it still legitimate to use $\vec{F} = i\vec{L} \times \vec{B}$?

44. *Magnetic force between two moving charged particles*

Particle 1 of charge q_1 moves with velocity \vec{v}_1 , and particle 2 of charge q_2 moves with velocity \vec{v}_2 . They are separated by a distance r_{12} and the unit vector from particle 1 to particle 2 is \hat{r}_{12} .

a. Combine the magnetic force law ($q\vec{v} \times \vec{B}$) and the Biot-Savart law to show that the magnetic force on particle 2 due to particle 1 is

$$\vec{F}_{\text{on 2 by 1}} = \frac{\mu_0}{4\pi} \frac{q_1 q_2}{r_{12}^2} \vec{v}_2 \times (\vec{v}_1 \times \hat{r}_{12}).$$

b. Suppose that particle 1 is heading due east, while particle 2, located due north of particle 1, is heading due north. Show that the magnetic force on particle 2 due to particle 1 is finite and points east, whereas the magnetic force on particle 1 due to particle 2 is zero. [This violation of Newton's third law shows that something is wrong with the above derivation. At fault is our use (actually misuse) of the Biot-Savart law, which applies only for steady currents but which we have used for the transient current of a single moving charge. The moral of the story is that the result of part (a), which looks like a perfectly good analog to Coulomb's law, is not true in general.]

c. (Optional... very difficult.) Integrate the Biot-Savart law around a circuit to show that when two complete circuits interact magnetically, the magnetic force on circuit 1 due to circuit 2 is equal and opposite to the magnetic force on circuit 2 due to circuit 1.

45. *An island in the stream*

A straight conductor carrying current $i = 27.3$ mA splits into identical semicircular arcs as shown. What is the magnetic field at the center C of the resulting circular loop? *[[Clue: Think! No computation required.]]*

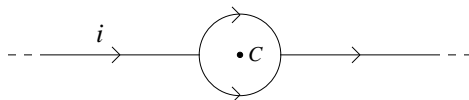

46. *Magnetic forces on wires*

The figure below shows a cross section of three parallel long straight wires, each of length $L \gg a$. Each wire carries current i in the direction shown. Find both (a) the magnetic field at and (b) the force on the lower right-hand wire. (Remember to give both magnitude and direction for vector quantities.)

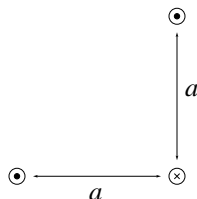

47. *The thick pipe of current*

Current i flows uniformly through a hollow cylindrical conductor of inner radius a and outer radius b .

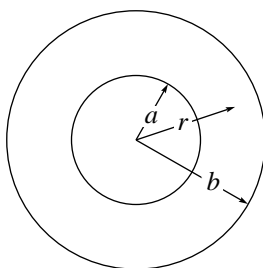

- a. Find the magnetic field for all values of r , the distance from the axis. In particular, show that for r within the conductor,

$$B(r) = \frac{\mu_0 i}{2\pi r} \frac{r^2 - a^2}{b^2 - a^2}.$$

- b. Show that B has the expected values when $r = a$, when $r = b$, and when $a = 0$.
 c. Sketch a graph of $B(r)$ as a function of r from $r = 0$ to $r \gg b$.

48. *Thick wire with a bore hole*

(*Clue:* Compare problem 13.)

- a. A long cylindrical wire carries current into the page, as shown below to the left. The current density J is uniform throughout the wire. Show that at point \vec{r} , the magnetic field is

$$\vec{B}(\vec{r}) = \mu_0 J \vec{r}_\perp / 2,$$

where \vec{r}_\perp denotes the vector resulting when \vec{r} is rotated clockwise by 90° .

- b. Now suppose that a cylindrical hole is bored out of the wire, as shown below to the right. The axes of the two cylinders are parallel and are separated by the vector \vec{a} . The rest of the wire continues to carry uniform current density J , but the bore hole carries no current. Show that the magnetic field is uniform throughout the bore hole and that it is given by

$$\vec{B}(\vec{r}) = \mu_0 J \vec{a}_\perp / 2,$$

- c. Show that the result of part (b) reduces to the proper limit in the case that $\vec{a} = 0$, and in the case that the bore hole has radius zero.

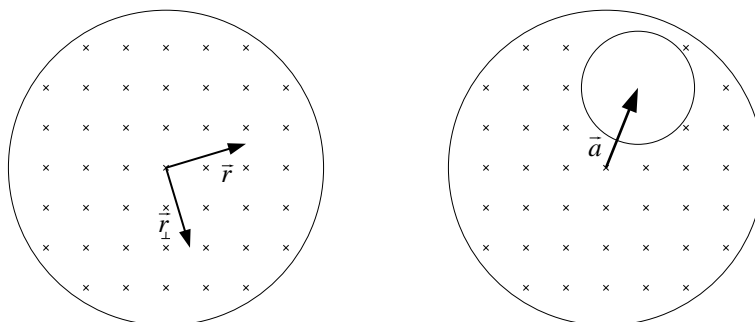

49. *Infinite sheet of current*

The figure shows a cross section of an infinite conducting sheet with current per unit y -length λ emerging perpendicularly from the page. (You may imagine the sheet to be constructed from many long, thin, parallel wires.)

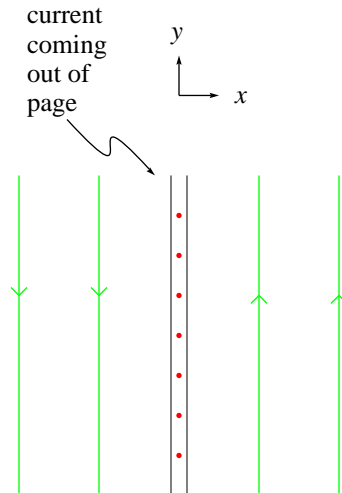

- Use Biot-Savart and symmetry arguments to convince yourself that $\vec{B}(\vec{r})$ is directed as shown in the figure and that its magnitude could only depend upon the distance $|x|$ from the sheet of current.
- Use Ampere's law to show that the magnitude of $\vec{B}(\vec{r})$ is $\mu_0\lambda/2$ which is, surprisingly, independent of the distance from the sheet.
- Two parallel infinite conducting sheets transport current per unit length λ as shown below. Show that outside of the two sheets the magnetic field vanishes, while between them it has magnitude $B = \mu_0\lambda$ and the direction indicated.

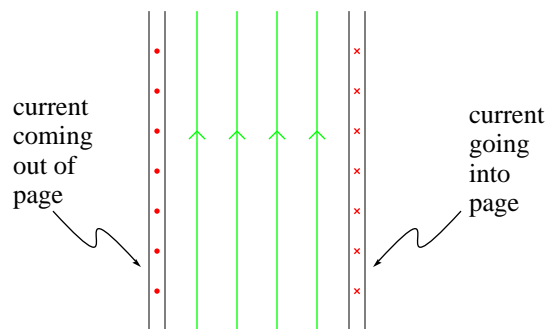

50. *Practice with Lenz's law, I*

In the figure below, two coils are wrapped around rubber rods. The circuit on the left has a battery and a variable resistance. The circuit on the right has only a galvanometer that registers the direction of current flowing through it. In which direction will current flow through the meter when (a) the two coils are moved closer together; (b) the variable resistance R is increased without moving the coils? [*Answers: (a) left; (b) right*]

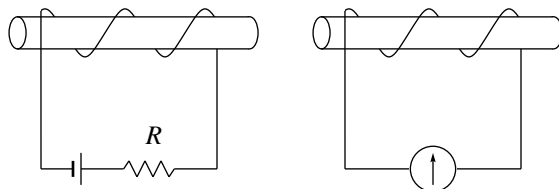

51. *Practice with Lenz's law, II*

The variable resistance R in the left-hand circuit below is increased. Does the current induced in the right-hand circuit flow clockwise or counterclockwise? [*Answer: clockwise*]

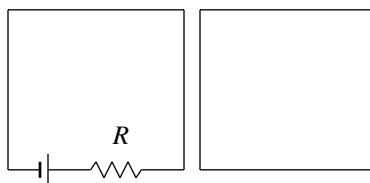

52. *Practice with Lenz's law, III*

When the switch is closed, one of the two light bulbs glows momentarily. Which one? [*Answer: bulb A*]

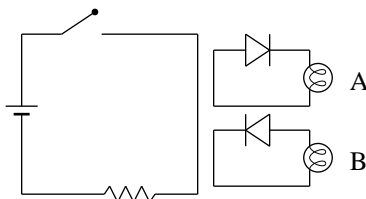

53. *The essence of induced electric field*

A long solenoid has 220 turns/cm and a radius of 1.6 cm. Outside that solenoid is a 120-turn coil of radius 1.8 cm and resistance 5.3Ω . The solenoid current drops at a steady rate from 1.5 A to zero during time interval 25 ms. What current is induced in the coil while the solenoid current drops?

54. *Falling wedding ring*

An N -loop coil of radius R and current i rests horizontally on a lab bench. Viewed from above, the current flows clockwise. A wedding ring of radius $r \ll R$ is held horizontally above the center of the coil, a distance z_0 above the lab bench, and then released at time $t = 0$. A current is induced in the wedding ring as it falls.

- a. (2 points) Does the current flow clockwise or counterclockwise (as viewed from above)?
- b. (8 points) The magnetic field a distance z above the center of the coil has magnitude

$$\frac{\mu_0 i N R^2}{2(R^2 + z^2)^{3/2}}.$$

Find an expression for the induced emf in the wedding ring as a function of z and t . (Neglect air resistance, buoyancy, and all other non-gravitational forces.)

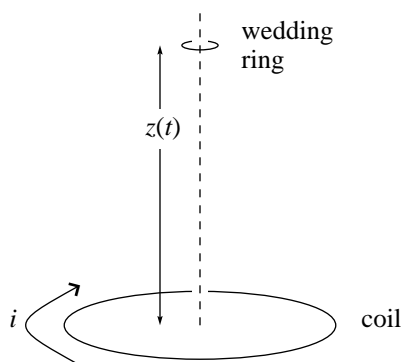

55. *Change of frequency*

In the “Measurement of Magnetic Field” lab, the source and pick-up coils are at certain positions and the pick-up coil registers an emf with peak-to-peak amplitude 38 mV. The frequency of AC current fed into the source coil is changed from 60 Hz to 30 Hz, with no other change. What is the peak-to-peak amplitude in the pick-up coil now?

56. *Alternating current generator*

A commercial AC generator works by rotating (at frequency f) a coil of N turns each with area A , immersed in a uniform magnetic field \vec{B} (produced by a permanent magnet). The coil is connected to co-rotating “slip rings”, against which carbon brushes slide to make contact with the circuit.

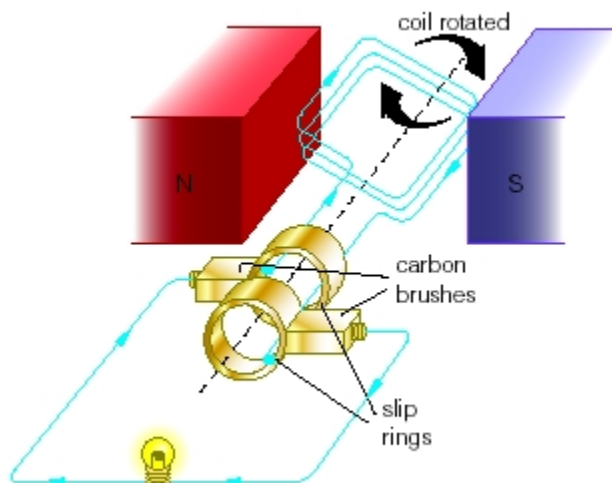

- a. Show that the emf induced in the coil is

$$\mathcal{E}(t) = 2\pi f N A B \sin(2\pi f t) = \mathcal{E}_0 \sin(2\pi f t).$$

- b. If the loop is rotated at 60.0 rev/s in a field of 0.500 T, what value of NA is needed to produce an \mathcal{E}_0 of 150 V?

57. *Primitive motor revisited*

A conducting bar of mass m slides without friction on two long horizontal rails. A uniform vertical magnetic field \vec{B} fills the region in which the rod moves. A battery of emf \mathcal{E} makes current run as shown: left on the top rail, down through the bar, and right back to the battery on the bottom rail.

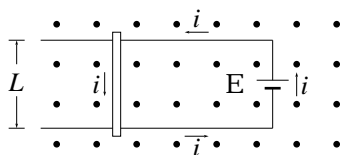

When this circuit is first set up the slide wire accelerates. But eventually the acceleration stops and the slide wire moves at constant velocity. Describe what's going on. Does the slide wire move left or right? Find a

formula for the terminal velocity. When the slide wire has reached terminal velocity, what is the current in the circuit?

58. *Induced electric field in a huge magnet*

The High Field Magnet Laboratory at Radboud University in Nijmegen, the Netherlands, has a pulsed magnet named “P2” capable of changing the field in a cylindrical region of diameter 23 mm from 0 to 54 T in 40 ms. While this change is taking place, what is the magnitude of the induced electric field 5.0 mm from the axis?

59. *Induced electric field*

A uniform magnetic field in a cylindrical region of radius R increases linearly from B_1 to B_2 in time T . Which of the following expressions gives the electric field induced a distance r from the cylinder’s axis ($r < R$)?

$$E(r) = \frac{r B_2 - B_1}{2 T}, \quad (1)$$

$$E(r) = \frac{R B_2 - B_1}{2 T}, \quad (2)$$

$$E(r) = \frac{r B_2}{2 T}, \quad (3)$$

$$E(r) = \frac{r B_2 - B_1}{2 T^2}. \quad (4)$$

Explain why the incorrect expressions must be rejected.

60. *Inductors in series*

Two inductors, L_1 and L_2 , separated by a large distance so that the magnetic field of one does not affect the other, are connected in series. Show that the equivalent inductance is

$$L_{eq} = L_1 + L_2.$$

61. *Inductors in parallel*

Two inductors, L_1 and L_2 , separated by a large distance so that the magnetic field of one does not affect the other, are connected in parallel. Show that the equivalent inductance is given through

$$\frac{1}{L_{eq}} = \frac{1}{L_1} + \frac{1}{L_2}.$$

62. Inductor in a circuit

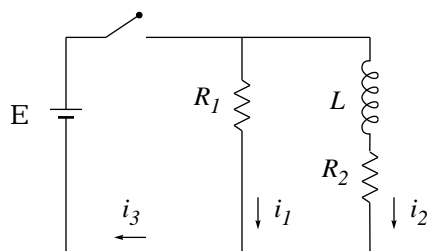

In this circuit, all elements are ideal, $\mathcal{E} = 10 \text{ V}$, $R_1 = 5.0 \Omega$, $R_2 = 10 \Omega$, and $L = 5.0 \text{ H}$. Immediately after the switch is closed, find: (a) i_1 , (b) i_2 , (c) i_3 , (d) the potential difference ΔV_2 across R_2 , (e) the potential difference ΔV_L across the inductor, and (f) the rate of change di_2/dt . A long time after the switch is closed, find: (g) i_1 , (h) i_2 , (i) i_3 , (j) ΔV_2 , (k) ΔV_L , and (l) di_2/dt .

63. A different RL circuit

The switch in the circuit below is closed at time $t = 0$. Here are six candidate expressions for the current through the inductor. Without solving the problem, give at least one reason why five of these candidates *cannot* be correct.

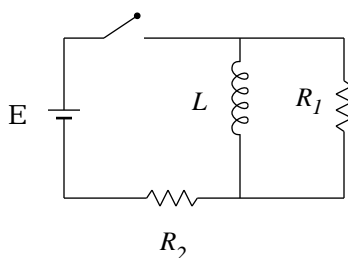

$$\frac{\mathcal{E}}{R_2} \left(1 - e^{-R_1 R_2 t / L(R_1 + R_2)} \right) \quad (1)$$

$$\frac{\mathcal{E}}{R_1} \left(1 - e^{-R_1 R_2 t / L(R_1 + R_2)} \right) \quad (2)$$

$$\frac{\mathcal{E}}{R_2} \left(2 - e^{-R_1 R_2 t / L(R_1 + R_2)} \right) \quad (3)$$

$$\frac{\mathcal{E}}{R_2} \left(1 - e^{-R_1 t / L(R_1 + R_2)} \right) \quad (4)$$

$$\frac{\mathcal{E}}{R_2} \left(1 - e^{-R_1 R_2 t / L(R_1 - R_2)} \right) \quad (5)$$

$$\frac{\mathcal{E}}{R_2} \left(1 - e^{-R_1 R_2 t / L(2R_1 + R_2)} \right) \quad (6)$$

64. *Shortcut to the period of an LC oscillator*

In class we solved a difficult ordinary differential equation to prove that the period of oscillation in an LC circuit is $T = 2\pi\sqrt{LC}$. The form of this result can be obtained very easily through dimensional analysis if you assume that the period can only depend upon the values of L and of C . Do it.

65. *Width of a resonance curve*

At resonance frequency ω_0 the current amplitude in an RLC circuit is maximized. There is a driving frequency ω_+ above ω_0 at which the current amplitude has half its maximum value, and similarly for a driving frequency ω_- below ω_0 . The so-called “full width at half maximum” for a resonance curve is defined as $\Delta\omega = \omega_+ - \omega_-$.

[[This is an important quantity in practical applications. For example, if you are designing a radio receiver using an RLC circuit to filter out unwanted radio stations, then $\Delta\omega$ should be much less than the frequency spacing between radio stations.]]

Show that

$$\Delta\omega = \frac{\sqrt{3}R}{L}.$$

Warning: If $x^2 = 4$, then $x = \pm 2$.

66. *Parallel RC circuit*

A capacitor C and a resistor R are connected *in parallel* across an ideal (zero resistance) sinusoidal AC generator with emf $\mathcal{E}(t) = \mathcal{E}_m \sin(\omega t)$.

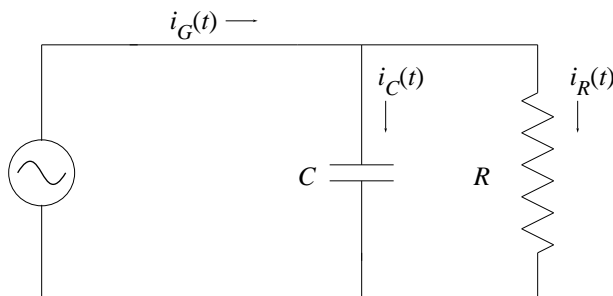

- Find $i_R(t)$, the current through the resistor.
- Find $q(t)$, the charge on the top plate of the capacitor.
- Find $i_C(t)$, the current through the capacitor branch.
- Find $i_G(t)$, the current through the generator.

67. AC network

In the circuit below, the constant-amplitude voltage generator delivers four times more current at very low frequencies than it does at very high frequencies. If $R_1 = 100 \Omega$, find the resistance R_2 .

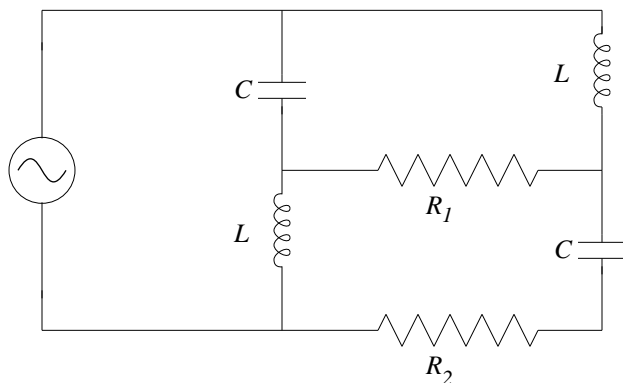

68. Parallel RL circuit

A resistor R and an ideal (zero resistance) inductance L are connected *in parallel* across an ideal (zero resistance) sinusoidal AC generator with emf $\mathcal{E}(t) = \mathcal{E}_m \sin(\omega t)$.

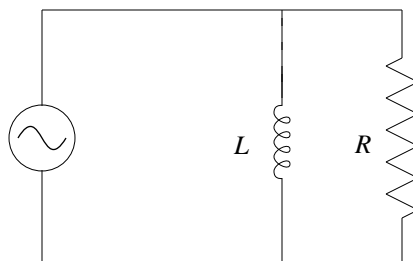

- At low frequencies, the amplitude of the generator current $i_G(t)$ is either **(i)** very small or else **(ii)** very large. Which is it and why?
- Find an expression for $i_G(t)$ that is approximately correct at high frequencies. Support your expression with a sentence or two of reasoning.
- At any frequency, will the amplitude of the generator current $i_G(t)$ **(i)** increase or **(ii)** decrease as the inductance L is increased? Why?

[Answers: (a.) At low frequencies (slow changes) the inductance acts like a piece of zero-resistance wire, so the generator current is very large. (b.) At high frequencies (rapid changes) the inductance works so effectively opposing change that almost no current flows through the inductance branch. The inductance

branch can be approximated by a broken wire so $i_G(t) \approx i_R(t) = (\mathcal{E}_m/R) \sin(\omega t)$. (c.) The inductance opposes current (just as a resistor does), so any increase in L causes a decrease in current amplitude. (This decrease is greater at high frequencies, but it exists at any frequency.)]

69. *Experimental detection of the Maxwell term*

In 1929 R. van Cauwenberghe succeeded in measuring directly, for the first time, the displacement current i_d between the plates of a parallel-plate capacitor to which a sinusoidal alternating voltage was applied. (“Experimental verification of electromagnetic equivalence between Maxwell displacement currents and conduction currents,” *Journal de Physique et le Radium*, **10** (1929) 303–312. For later work see D.F. Bartlett and T.R. Corle, “Measuring Maxwell’s displacement current inside a capacitor,” *Phys. Rev. Lett.* **55** (1985) 59–62.) Van Cauwenberghe used circular plates whose effective radius was 40.0 cm and whose capacitance was 100 pF. The applied voltage had a maximum value V_m of 174 kV and a frequency of 50.0 Hz.

- Show that the displacement current in a parallel-plate capacitor of capacitance C and with potential difference ΔV between plates is $i_d = C(d\Delta V/dt)$.
- What maximum displacement current was present between the plates in van Cauwenberghe’s apparatus?
- Speculate on why that applied voltage was chosen to be so high.

Measurements of this sort are so delicate that they were not performed in a direct manner until more than 60 years after Maxwell developed the concept of displacement current!

70. *How does i^2R heating power get to a resistor?*

Consider a cylindrical resistor of length ℓ , radius a , and resistivity ρ , carrying a current i .

- Show that the Poynting vector \vec{S} at the resistor’s surface points perpendicularly into the resistor, and has magnitude $\rho i^2/(2\pi^2 a^3)$.
- Find the rate at which electromagnetic energy flows into the resistor by multiplying the magnitude of \vec{S} times the area of the side of the cylinder.
- Show that this rate is equal to i^2R .

In other words, the energy that appears in a resistor as thermal energy does not enter it through the connecting wires, but instead travels through the empty space surrounding the wires and resistor.

71. *Energy flow in circuits, qualitative*

A cylindrical ideal battery sends current through ideal wires to a cylindrical resistor. Sketch the electric and magnetic field lines in the vicinity of the battery and of the resistor, then draw in the Poynting vector at the surface of each. Conclude that energy is seeping out of the sides of the battery and into the sides of the resistor.

72. *Stacks of polarizing sheets*

A beam of unpolarized light is incident on a stack of $n+1$ ($n \geq 1$) polarizing sheets. The polarizing direction of the first sheet is vertical, and all the rest are oriented at an angle of $90^\circ/n$ to the right of the previous sheet (thus the second is $90^\circ/n$ to the right of vertical, the third is $2(90^\circ/n)$ to the right of vertical, and the last is 90° to the right of vertical). Show that the fraction of the incident intensity transmitted by the system is

$$\frac{1}{2} \cos^{2n}(90^\circ/n).$$

What are the limits of this expression when $n = 1$ and when $n \rightarrow \infty$? Show that the fraction transmitted increases monotonically as n increases.

73. *Circularly polarized standing waves*

At the fall 1997 meeting of the Ohio Section of the American Physical Society, two friends of mine engaged in a heated argument concerning circularly polarized standing light waves. Both agreed that—as mentioned in class—the electric field behaved like a jump rope. But they disagreed on how the magnetic field behaved: Professor Ron Stoner of Bowling Green State University maintained that the magnetic field would point in the same plane as the electric field, whereas Professor Glenn Julian of Miami University maintained that it would point in the plane perpendicular to the electric field. Resolve the controversy by politely but decisively proving one professor wrong. (*Clue:* Consider the vertical plane that passes through the “turners” of the “jump rope”. Apply Faraday’s law to a rectangular loop within that plane at the instant the electric field points vertically.)

74. *N-slit interference*

The Young double-slit interference experiment is repeated with N instead of two slits. Adjacent slits are separated by a distance d , and $N \geq 2$. At what angles θ are the interference maxima located? *Do not solve this problem*, but instead show that only one of the five candidate solutions advanced below is feasible. (In all cases $m = 0, \pm 1, \pm 2, \dots$)

$$d \sin \theta = (m + \frac{1}{2})\lambda \tag{1}$$

$$d \sin \theta = mN\lambda \tag{2}$$

$$d \sin \theta = m[\lambda + (N - 2)\lambda^2] \tag{3}$$

$$d \sin \theta = m\lambda \tag{4}$$

$$d \sin \theta = m\lambda \left[1 + (N - 2) \frac{d^2}{\lambda^2} \right] \tag{5}$$

[*Answer:* The first and second candidates give incorrect results for the special case $N = 2$. The third is dimensionally inconsistent. The fourth is feasible and, in fact, correct. When $N > 2$ the fifth will have $\sin \theta$ large when λ/d is small, which (i) does not give the correct limit of ray optics for small wavelengths, and (ii) raises the specter of $\sin \theta > 1$.]

75. *Sandstone quarry*

Eighty years ago sandstone quarrying was an important industry in the Oberlin area. (See *Sandstone Center of the World* by James Hieb (Lulu, 2007).) Quarry operators would sometimes flood the bottoms of their quarries knee-deep in water to make it easier for workers to carry stone. Suppose a particular sandstone slab weighs 533 newtons in air and 293 newtons when completely immersed in water. Taking the density of water to be exactly 1000 kg/m^3 , what is the density of sandstone?

76. *True love*

Your (boy/girl)friend gives you a shiny ring of silver color. The ring has no gemstone, instead it's a uniform metallic band inscribed with the aphorism "I love you as much as I love physics." You borrow a jeweler's spring scale and hang the ring from it on a thread: the spring scale reads 12.3 carats. Then you immerse the ring in a cup of water: the spring scale now reads 11.7 carats. Taking the density of water to be 1.00 g/cm^3 , which substance do you think your new ring is made of?

substance	density (g/cm^3)
nickel	8.9
silver	10.5
palladium	12.0
"white gold" alloy	15.4
platinum	21.4

77. *Rubber band work*

A rubber band displays the same unusual property that water does between 0° C and 4° C , namely it contracts when its temperature increases. A block of mass 2.147 kg is suspended from a rubber band of mass 17.04 g . An electric hair dryer increases the rubber band's temperature by 3.141 K and the block rises 2.733 cm . What is the change in the rubber band's internal energy? (The heat capacity of rubber is $2.010 \text{ J/g}\cdot\text{K}$.)

78. *Carbon sequestration*

(Acknowledgement: This problem derives from Professor John Scofield's work on the American Physical Society's Panel On Public Affairs, Study Group on Energy Efficiency, report issued 16 September 2008.) One possible "clean coal" technology relies on so-called "carbon sequestration": instead of CO_2 , a greenhouse gas, being released into the atmosphere, it is pumped down into rock formations and stored far below the Earth's surface. The first step in such a process would be purification: Start with air (at pressure p_i and temperature T) that has mole fraction f_{CO_2} of CO_2 , and end up with pure CO_2 at the same pressure and temperature. The question is, how much work would this purification process require? Show that if this process is executed isothermally, and if air and CO_2 can be treated as ideal gases, then the minimum work needed to purify N moles of CO_2 is $-NRT \ln(f_{\text{CO}_2})$. Does this expression have the proper sign? The proper limits when $f_{\text{CO}_2} = 1$ and when $f_{\text{CO}_2} = 0$?

Clues: Suppose we had a filter that passed CO_2 but no other gas. Place that filter at the base of a piston cylinder, with the piston all the way down. Pull back the piston to draw in an appropriate amount of CO_2 .

Now we have pure CO_2 , but its pressure is down to $f_{\text{CO}_2}p_i$. Replace the filter with a piece of wall and thrust in the piston until the pressure is back up to p_i . Both of these strokes require work.

79. *Adiabatic expansion*

Do not solve this problem:

An ideal gas with heat-capacity ratio γ expands adiabatically from initial temperature T_i and volume V_i to final volume V_f . If there are n moles of gas, how much work does the gas perform?

Instead, explain briefly why four of these five candidate answers must be wrong.

$$\frac{(n-1)RT_i}{\gamma-1} \left[1 - \left(\frac{V_i}{V_f} \right)^{\gamma-1} \right] \quad (1)$$

$$\frac{nRT_i}{\gamma-1} \left[1 - \left(\frac{V_i}{V_f} \right)^{\gamma-1} \right] \quad (2)$$

$$\frac{nRT_i}{\gamma-1} \left[1 - \left(\frac{V_f}{V_i} \right)^{\gamma-1} \right] \quad (3)$$

$$\frac{nRT_i}{\gamma-1} \left[\left(\frac{V_i}{V_f} \right)^{\gamma-1} - 1 \right] \quad (4)$$

$$\frac{nRT_i^2}{\gamma-1} \left[1 - \left(\frac{V_i}{V_f} \right)^{\gamma-1} \right] \quad (5)$$

80. *Helium engine*

A Carnot engine acts quasistatically between two heat baths at atmospheric pressure: The high temperature bath is liquid water in equilibrium with steam, the low temperature bath is liquid water in equilibrium with ice. The working substance of the Carnot engine is Helium, which at these temperatures can be approximated to high accuracy as an ideal gas with $\gamma = \frac{5}{3}$. In the first leg of the Carnot cycle the Helium expands isothermally from 1.47 m^3 to 3.96 m^3 . What is the engine's efficiency?

81. *Thermoelectric engine*

A single loop circuit is made with two different kinds of wire, and the two junctions are placed at different temperatures. It is discovered experimentally that an electric potential difference arises between the two junctions. This so-called Seebeck effect is responsible for the workings of thermocouples.

For example, if one wire is made of copper, and the other of nickel, then a potential difference of $26.3 \mu\text{V}$ will arise for every K of temperature difference. (This datum derives from the 1981 *Physics Vade Mecum*, table 22.09. Strangely enough, I could not find this information on the Internet!) This potential difference can act as a seat of emf driving current around the circuit and, of course, this current can drive an electric motor.

Suppose the two junctions are at 400 K and at 200 K, the resistance of the loop plus electric motor is 26.3Ω , and the apparatus operates quasistatically. What is the efficiency?

82. *Stirling cycle*

The *Stirling cycle* heat engine was invented in 1816 by the Reverend Robert Stirling. In the idealized form of this cycle, the working substance expands at constant temperature T_H from volume V_A to volume V_B . Then the working substance is cooled at constant volume to temperature T_L . Then it contracts at constant temperature from volume V_B to volume V_A . Finally it is heated at constant volume back to the original temperature T_H . If the working substance is n moles of an ideal gas, find a formula for (a) the work done and (b) the heat absorbed in one cycle of this engine.

83. *Otto cycle*

The heat engine in most gasoline-powered automobile engines works following the *Otto cycle*. (Patented by Eugenio Barsanti and Felice Matteucci in 1854 but made practical by Nikolaus Otto in 1876.) There are four steps in the idealized form of this cycle:

1. The working substance at initial temperature T_{\min} and volume V_{\max} is compressed adiabatically to volume V_{\min} .
2. Next the temperature increases to T_{\max} with no change in volume.
3. Then the working substance expands adiabatically to the initial volume V_{\max} .
4. Finally the temperature decreases to its initial value T_{\min} with no change in volume.

If the working substance is n moles of an ideal gas with heat-capacity ratio γ , show that the work done during one cycle of this engine is

$$\frac{nRT_{\max}}{\gamma - 1} \left[1 - \left(\frac{V_{\max}}{V_{\min}} \right)^{\gamma-1} \right] + \frac{nRT_{\min}}{\gamma - 1} \left[1 - \left(\frac{V_{\min}}{V_{\max}} \right)^{\gamma-1} \right].$$

84. *Entropy change*

At low temperatures the heat capacity of a ceramic is given to close approximation by $C_V = k_D T^3$. Find the entropy change of this ceramic when its temperature changes from T_i to T_f . (Both temperatures are low enough that the approximation is appropriate.)